

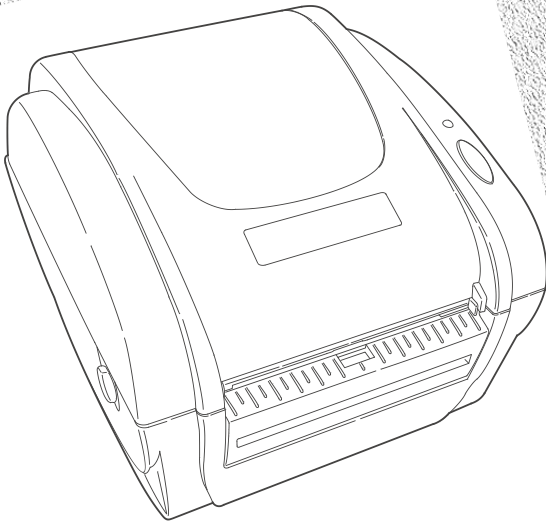

Equipment Manual

Monarch®
9416® XL®
Printer



Drucksysteme Janz & Raschke GmbH
Osterbrooksweg 71, D-22869 Schenefeld
Tel.: +49(0)40 - 840 509 0
Fax: +49(0)40 - 840 509 29
Email: kontakt@jrdrucksysteme.de
www.jrdrucksysteme.de



Each product and program carries a respective written warranty, the only warranty on which the customer can rely. Paxar reserves the right to make changes in the product, the programs, and their availability at any time and without notice. Although Paxar has made every effort to provide complete and accurate information in this manual, Paxar shall not be liable for any omissions or inaccuracies. Any update will be incorporated in a later edition of this manual.

©2004 Paxar Americas, Inc. a subsidiary of Avery Dennison Corp. All rights reserved. No part of this publication may be reproduced, transmitted, stored in a retrieval system, or translated into any language in any form by any means, without the prior written permission of Paxar Americas, Inc.

WARNING

This equipment has been tested and found to comply with the limits for a Class A digital device, pursuant to Part 15 of the FCC Rules. These limits are designed to provide reasonable protection against harmful interference when the equipment is operated in a commercial environment. This equipment generates, uses, and can radiate radio frequency energy and, if not installed and used in accordance with the instruction manual, may cause harmful interference to radio communications. Operation of this equipment in a residential area is likely to cause harmful interference in which case the user will be required to correct the interference at his own expense.

CANADIAN D.O.C. WARNING

This digital apparatus does not exceed the Class A limits for radio noise emissions from digital apparatus set out in the Radio Interference Regulations of the Canadian Department of Communications.

Le présent appareil numérique n'émet pas de bruits radioélectriques dépassant les limites applicables aux appareils numériques de la classe A prescrites dans le Règlement sur le brouillage radioélectrique édicté par le ministère des Communications du Canada.

Trademarks

MONARCH® and 9416®, and XL® are trademarks of Paxar Americas, Inc. Paxar® is a trademark of Paxar Corporation.
Avery Dennison® is a trademark of Avery Dennison Corporation.
Microsoft and MS-DOS are registered trademarks of Microsoft Corporation.
Windows is a registered trademark of Microsoft in the U.S. and other countries.
Centronics is a registered trademark of Centronics Data Computer Corporation.



TABLE OF CONTENTS

GETTING STARTED	1-1
Using This Manual	1-1
Audience	1-1
Additional Documentation	1-2
Unpacking the Printer.....	1-2
Connecting the Power Supply.....	1-3
Connecting the Communication Cable	1-4
USB Port	1-5
Reading the Indicator Light	1-6
LOADING SUPPLIES & PRINTING	2-1
Loading Supply for Non-Peel Mode	2-2
Loading Labels for Peel Mode	2-8
Loading Fan-Fold Supplies	2-14
Calibrating the Supply	2-16
Adjusting the Black Mark/Die Cut Sensor	2-17
Printing.....	2-18
CARE & MAINTENANCE	3-1
Clearing Supply Jams.....	3-1
Cleaning the Printhead.....	3-2
Cleaning the Platen Roller and Printer	3-3

TROUBLESHOOTING **4-1**

- Printing Problems and Solutions4-1
- Printing Test Labels4-4
- Calibrating the Supply4-5

SPECIFICATIONS & ACCESSORIES **A-1**

- Printer Specifications A-1
- Supply Specifications A-2
- Printer Accessories A-2

GETTING STARTED

1

The Monarch® 9416® XL® is a desktop thermal direct printer. It can print labels, tags or receipts (with or without bar codes) in peel mode (one label at a time) or non-peel mode (labels in strips).

Using This Manual

Following is a summary of the contents of this manual:

	Chapter	Contents
1	Getting Started	Unpacking the printer, connecting the cables, and reading the indicator light.
2	Loading Supplies & Printing	Loading labels, tags, and receipt paper and printing.
3	Care & Maintenance	Clearing supply jams and cleaning the printer.
4	Troubleshooting	Common problems and their solutions.
A	Specifications & Accessories	Printer and supply specifications and accessory part numbers.

Audience

The *Equipment Manual* is for the person who prints and applies labels.

Information in this document supersedes information in previous versions. Check our Web site (www.monarch.com) for the latest documentation and release information.

Additional Documentation

The printer uses Monarch® Printer Control Language II (MPCL II) to create labels for printing. The *Packet Reference Manual* describes how to create format and batch packets for printing labels, how to configure the printer, and perform other advanced techniques.

You can download the online version of the *Packet Reference Manual* from our Web site (www.monarch.com).

Unpacking the Printer

Keep all packaging material in case you need to move or return the printer. After you unpack the printer, you should have a

- ◆ 9416 printer
- ◆ Power Supply
- ◆ *Quick Reference*
- ◆ CD-ROM that contains software and manuals.

If any items are missing, contact Monarch for replacement parts.

Connecting the Power Supply

Caution: Do not touch the electrical connectors while setting up the printer. Electrostatic discharge can damage or destroy the printhead or electronic components.

To connect the power supply:

1. Place the printer in a location that allows easy access to the front of the printer.

Note: Never operate the printer while it rests on its side or upside down.

2. Place the power supply in a suitable location, preferably on the floor, near an electrical outlet.
3. Turn off the printer. Press the switch on the back of the printer to the OFF position (O).
4. Plug the three-hole end of the AC adapter cable into the three-pronged outlet in the power supply.
5. Plug the round end of the power supply cable (labeled “printer”) into the socket at the back of the printer.

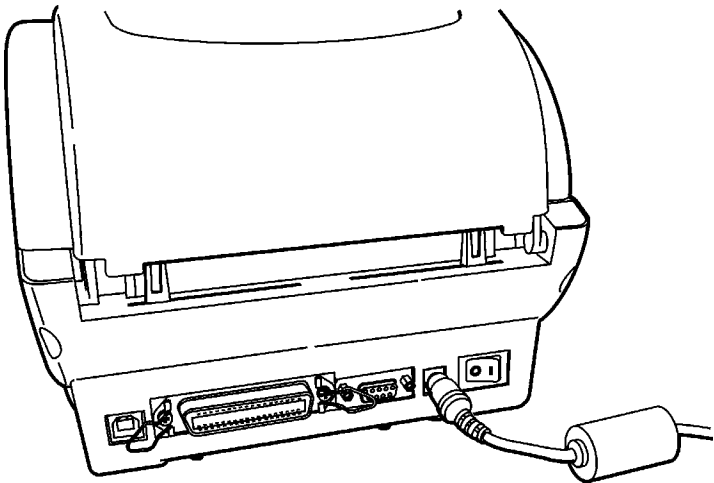

6. Plug the three-pronged end of the AC adapter cable into a grounded electrical outlet.

WARNING: The printer and power supply should never be operated in a location where either one can get wet. Personal injury could result.

Connecting the Communication Cable

Before the printer can accept print jobs from the host, you must

- ◆ connect the communication cable to the printer and the host.
- ◆ set the communication values on the printer to match those at the host (only required if you are using the serial port).

For parallel communication:

1. Turn off the printer before connecting the cable.
2. Connect a parallel printer cable from the computer to the parallel port at the back of the printer.

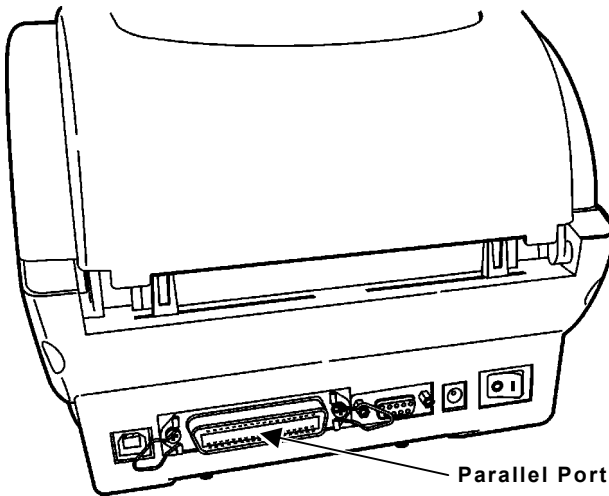

3. Secure the cable with the spring clips.

For serial communication:

1. Turn off the printer before connecting the cable.
2. Connect a serial printer cable from the host to the serial port at the back of the printer.

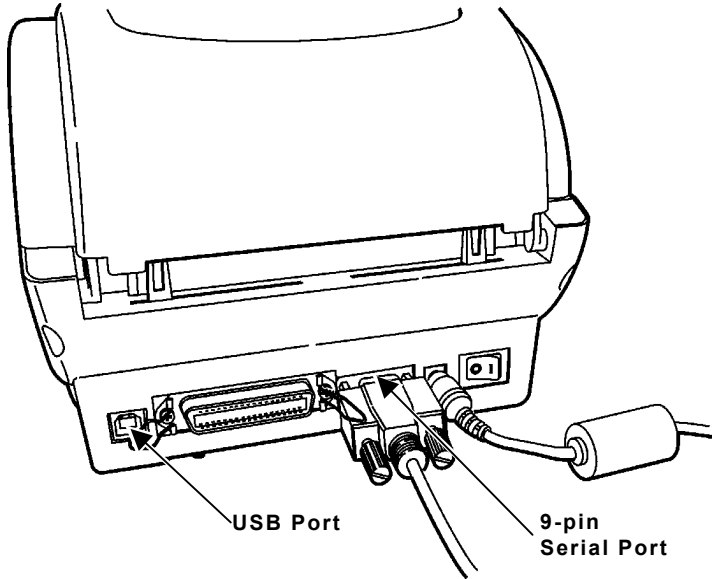

3. Secure the cable with the connecting screws.
The factory defaults are 9600 Baud, 8-bit data frame, 1 stop bit, no parity, and DTR flow control.
To set communication values, refer to the *Packet Reference Manual*.

USB Port

The printer has a USB (Universal Serial Bus) Version 2.0 communication port.

Reading the Indicator Light

The indicator light monitors the printer's status.

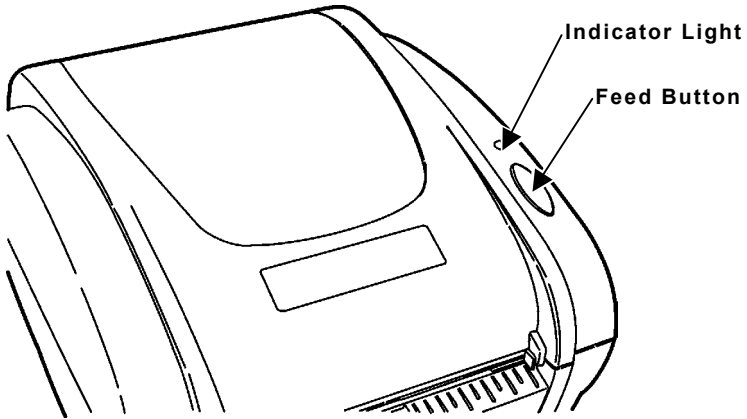

Indicator Light	Description
GREEN	Printer is on and ready to use.
FLASHING GREEN	Printer is paused. Press the FEED button to resume printing.
FLASHING RED	Printer error condition. See Chapter 4, "Troubleshooting" for error conditions and solutions.
ORANGE	The system is detecting the supply.
No light	Printer is off. Make sure the power supply is connected properly. See "Connecting the Power Supply" earlier in this chapter.

LOADING SUPPLIES & PRINTING

2

This chapter describes how to

- ◆ load a roll of labels or tags for non-peel mode
- ◆ load a roll of labels for peel mode
- ◆ load fan-fold supplies
- ◆ print.

Loading Supply for Non-Peel Mode

The printer can print on thermal-direct labels and tags. Make sure the black mark/die cut sensor is set correctly for your supply type. See “Adjusting the Black Mark/Die Cut Sensor,” for more information.

Note: If you run out of supply while printing, do not turn off the printer when reloading the supply. You may lose your data. The printer resumes printing when reloaded.

1. Remove and discard the tape from a new roll of supply.
2. Press the cover release levers (located on both sides of the printer) towards the front of the printer to release the cover.

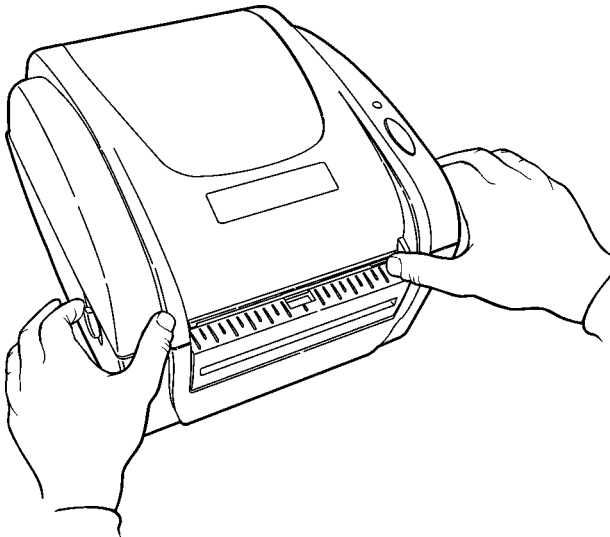

3. Lift open the cover.

4. Remove the supply holder guide from one end of the supply holder. (The supply holder is normally attached with a line to the inside of the printer, not free-standing as shown below. Do not cut the line.)

Supply Holder Guides

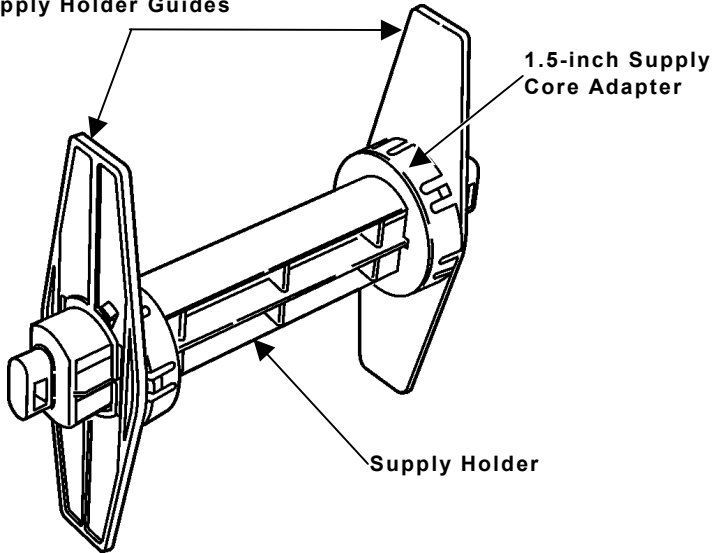

5. Slide a roll of supply onto the supply holder.
Note: If the core diameter on your roll of supply is 1 inch in diameter, remove the 1.5-inch supply core adapters from the supply guide holders.
6. Slide the supply holder guide back onto the end of the supply holder. If you are using the supply core adapters for 1.5-inch core supply, make sure to push the supply core adapters into the ends of the supply.

7. Insert the ends of the supply holder into the slots in the supply roll mount.

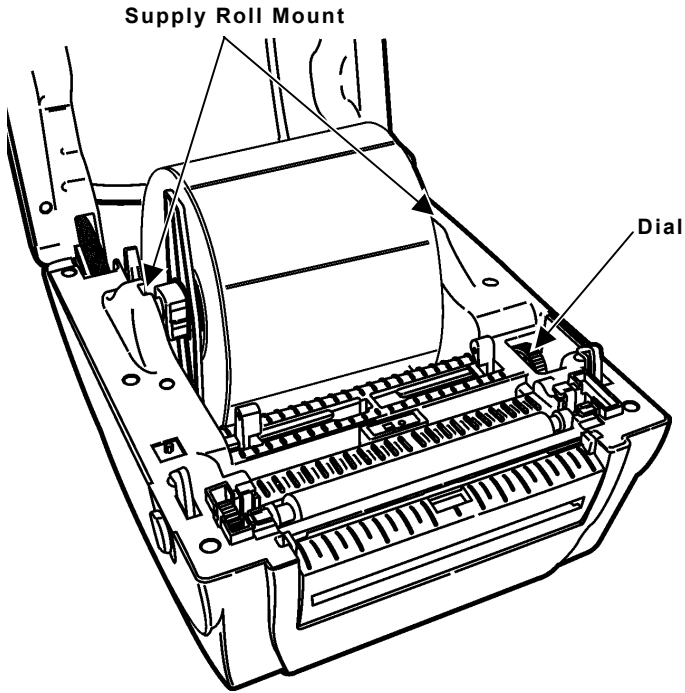

Important: Make sure the plastic line attaching the supply holder to the printer is tucked down out of the way of the supply holder and supply holder guides. Otherwise, the plastic line may wrap around the supply holder or get caught on the supply holder guides.

8. Turn the dial to adjust the supply guides to their widest position.

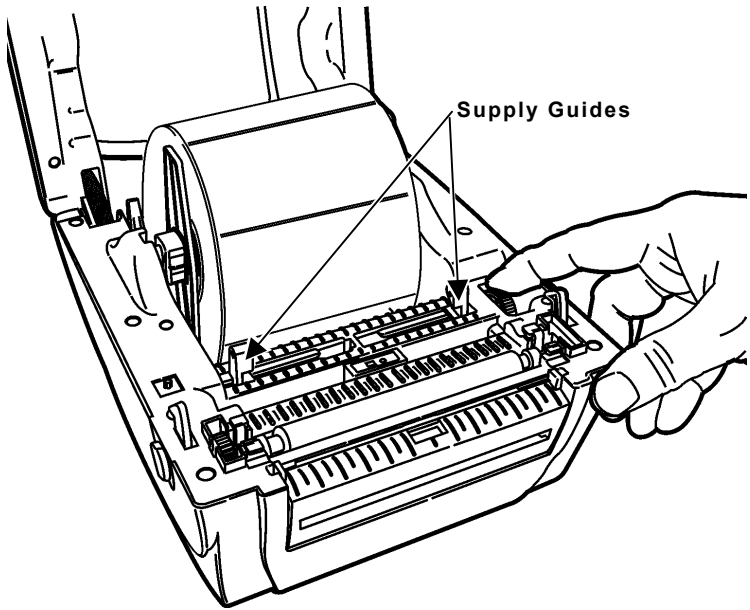

9. Feed the supply, printing side up, under the supply guides and over the platen roller.

10. Press the supply under the supply guides.

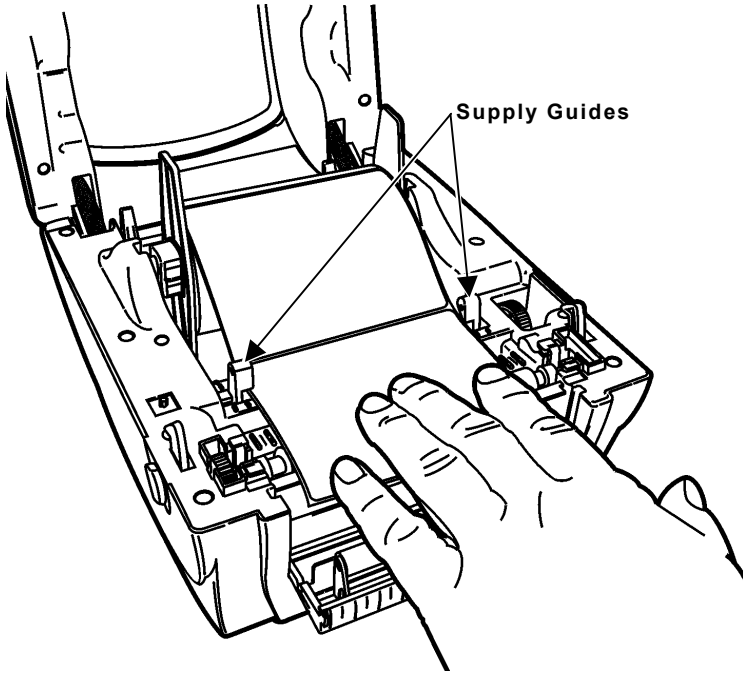

11. Turn the dial to move the supply guides so that they barely touch the edges of the backing paper.

12. Close the cover until it locks in place.
13. Press the **FEED** button. The indicator light should be GREEN.

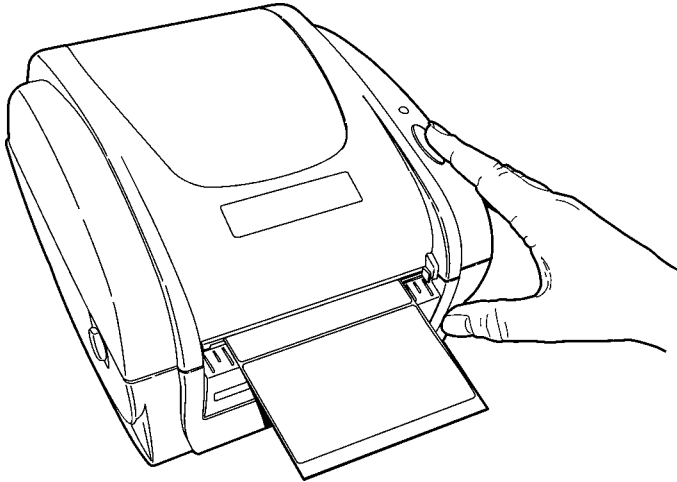

14. Calibrate the supply, if necessary. See “Calibrating the Supply,” for more information.

Loading Labels for Peel Mode

Peel mode separates the label from the backing paper while printing.

Note: The minimum label length for peeling is 0.75-inches (19 mm). Hold the leading edge of peeled labels when printing on supply longer than six inches.

1. Press the cover release levers (located on each side of the printer) towards the front of the printer to release the cover.
2. Lift open the cover.
3. Pull out the peel door located on the front of the printer to display the peel roller and the peel bar.

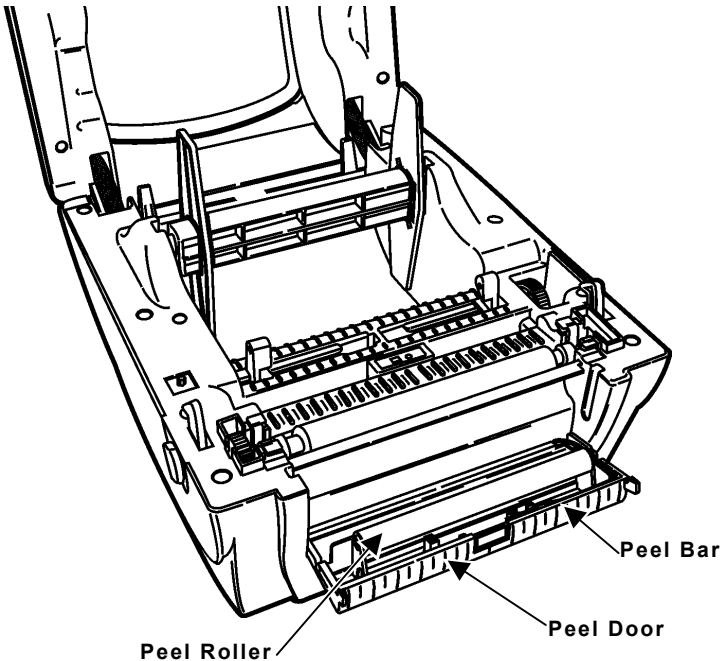

4. Remove the supply holder guide from one end of the supply holder. (The supply holder is normally attached with a line to the inside of the printer, not free-standing as shown below. Do not cut the line.)

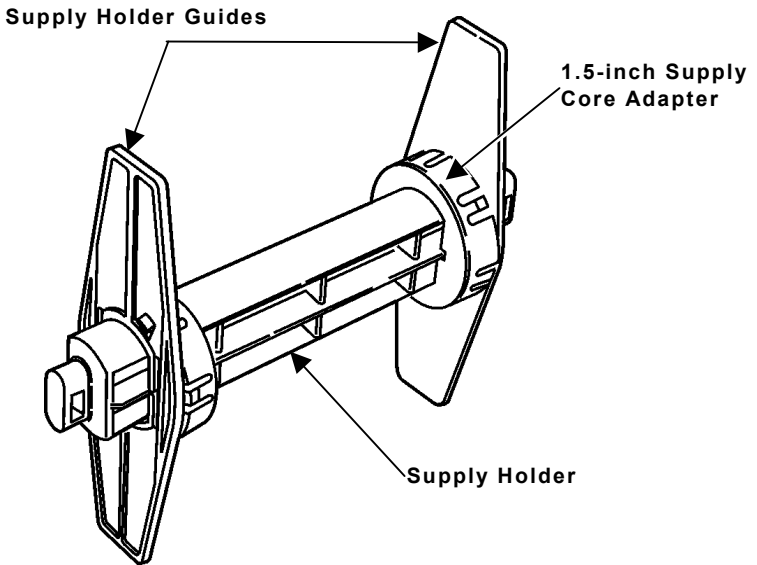

5. Slide a roll of labels onto the supply holder.
Note: If the core diameter on your roll of labels is 1-inch in diameter, remove the 1.5-inch supply core adapters from the supply holder guides.
6. Slide the supply holder guide back onto the end of the supply holder. If you are using the supply core adapters for 1.5-inch core supply, make sure to push the supply core adapters into the ends of the supply.

7. Insert the ends of the supply holder into the slots in the supply roll mount.

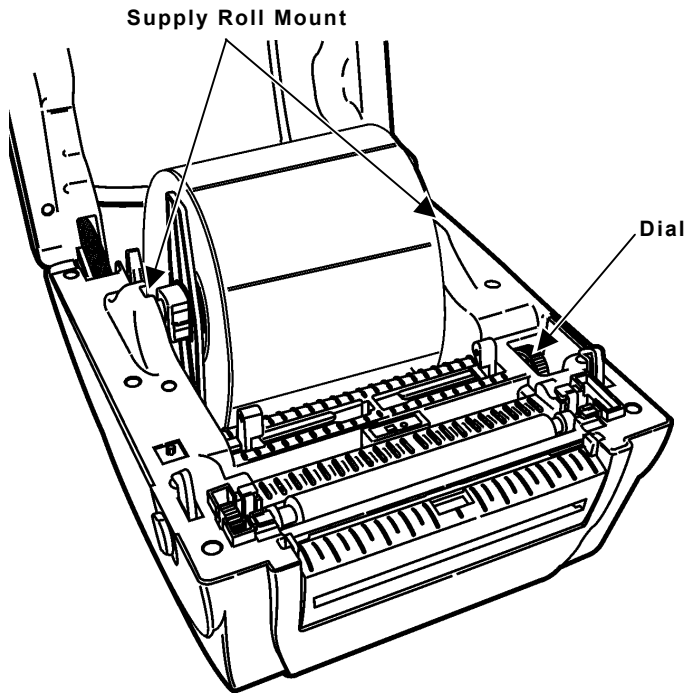

Important: Tuck the plastic line attaching the supply holder to the printer down out of the way of the supply holder and supply holder guides. Otherwise, the plastic line may wrap around the supply holder or get caught on the supply holder guides.

8. Turn the dial to adjust the supply guides to their widest position.
9. Remove the first two labels from the backing paper.

10. Feed the labels, printing side up, through the supply guides and over the platen roller.

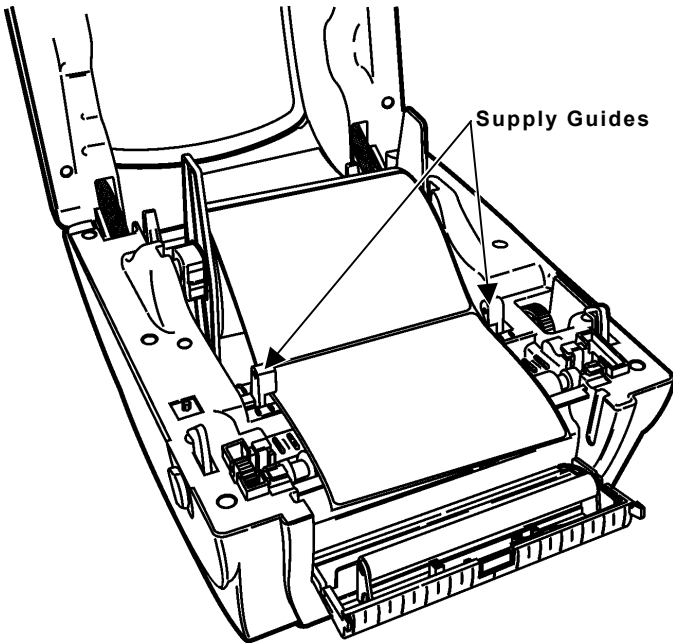

11. Press the labels under the supply guides.
12. Turn the dial to move the supply guides so that they barely touch the edges of the backing paper.

13. Feed the backing paper under the peel roller and through the peel door opening.

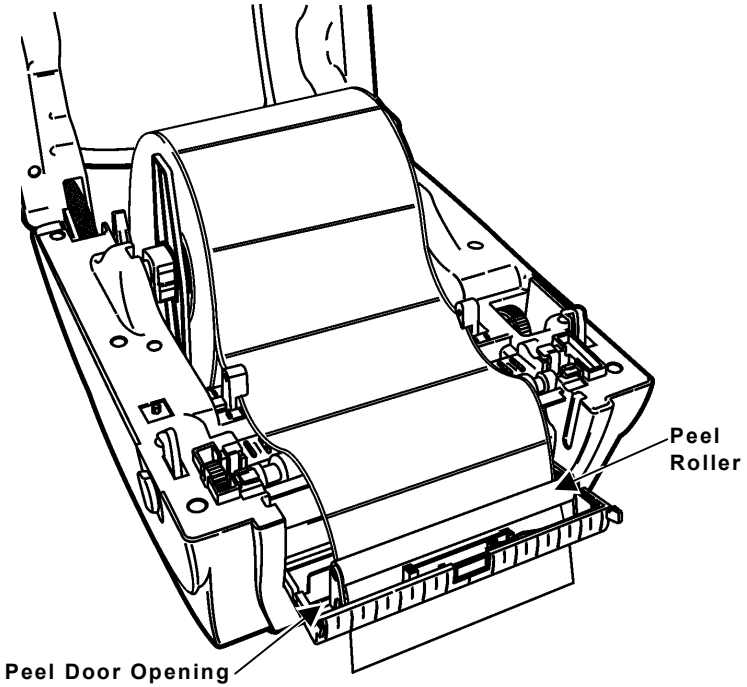

14. Push the peel door closed until it locks.
15. Close the cover until it locks in place.

16. Press the **FEED** button. A label separates from the backing paper. Remove the peeled label and another label prints.

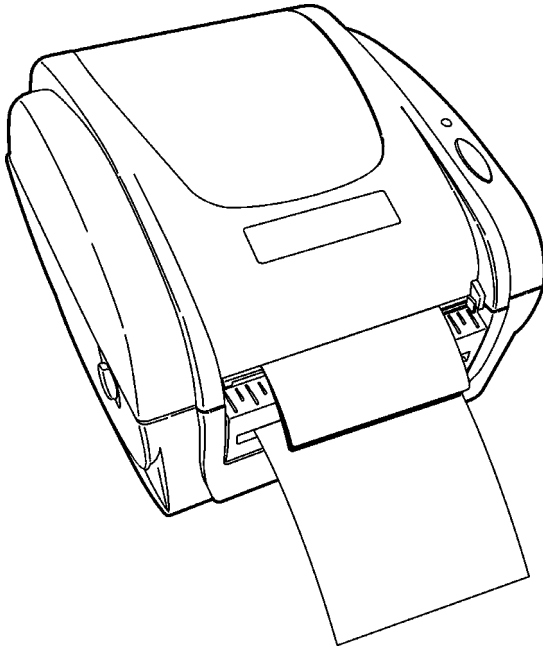

- Note:** Hold the leading edge of peeled labels when printing on supply longer than six inches.
17. Calibrate the supply, if necessary. See “Calibrating the Supply,” for more information.

Loading Fan-Fold Supplies

1. Place a stack of fan-fold supplies behind the printer, label side up.
- Note:** You may have to move the printer to allow room for the supply.
2. Push the external supply guides (located on the back of the printer) out to their widest position.

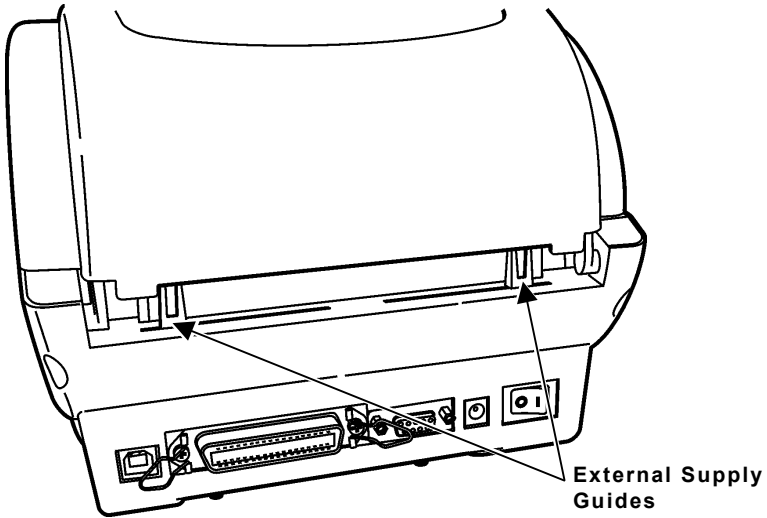

3. Feed the fan-fold labels, printing side up, into the external supply slot on the back of the printer and through the external supply guides.
4. Adjust the external supply guides so that they barely touch the edge of the supply.
5. Press the cover release levers (located on each side of the printer) towards the front of the printer to release the cover.

6. Lift open the cover. Leave the supply holder in the printer.
7. Turn the dial to adjust the internal supply guides to their widest position.
8. Feed the fan-fold labels through the supply guides, over the supply holder and over the platen roller.

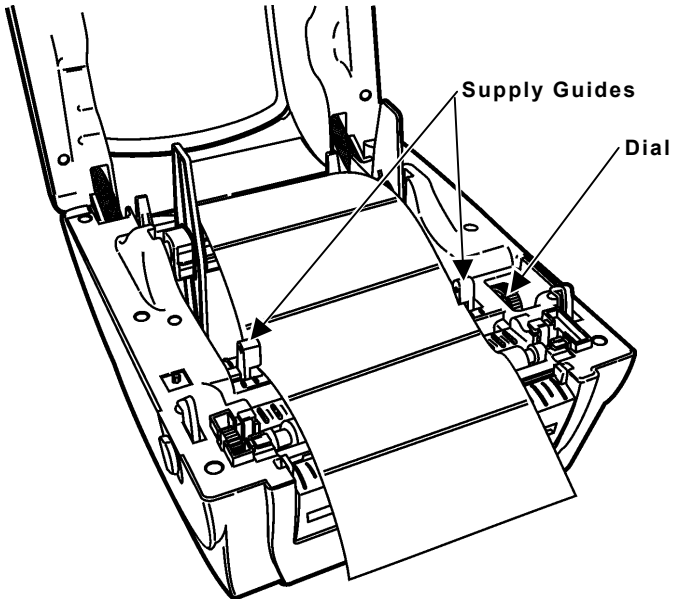

9. Press the fan-fold labels under the supply guides.
10. Turn the dial to move the supply guides so that they barely touch the edges of the supply.

11. Close the cover until it locks in place.
12. Press the **FEED** button. The indicator light should be GREEN.

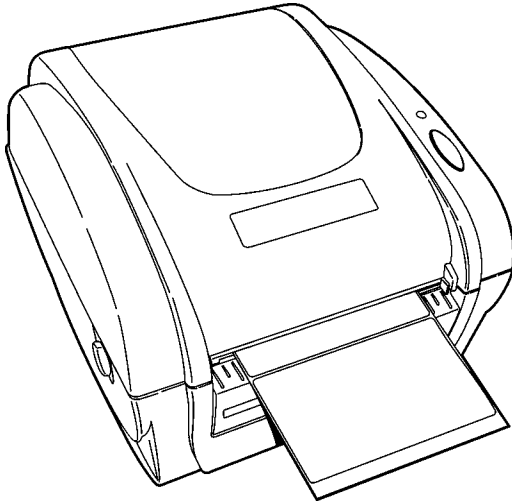

13. Calibrate the supply, if necessary.
See “Calibrating the Supply,” for more information.

Calibrating the Supply

1. Turn off the printer.
2. Press and hold the **FEED** button while turning on the printer.
3. Release the **FEED** button after the indicator light starts flashing ORANGE. The printer calibrates the black mark or die cut sensor, measures the label length, and prints the test labels.
4. To resume normal printing, turn off the printer, wait two seconds, then turn it back on again.

Adjusting the Black Mark/Die Cut Sensor

The printer has a black mark/die cut sensor, which it uses to sense and properly calibrate supplies. Black mark supply has sense marks (black marks) on the back of them. Die cut supply does not have any black marks.

For die cut supplies, make sure the sensor is in the detented position and the middle of the square lens lines up with the arrow inside the printer.

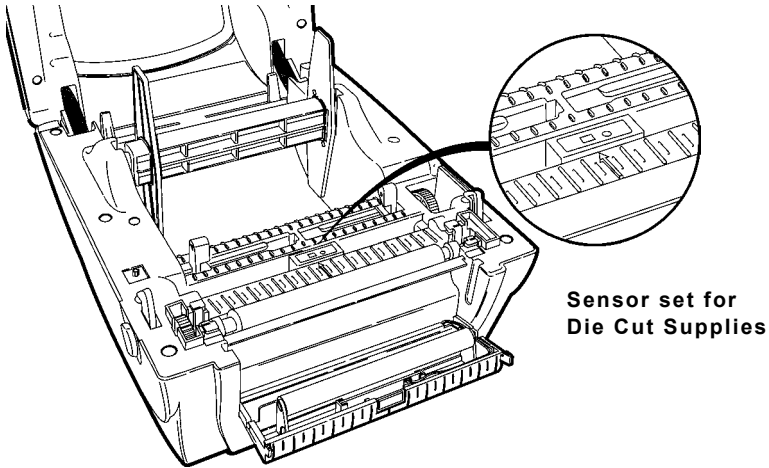
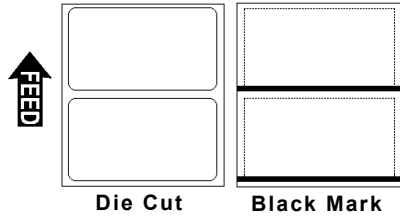

For black mark supplies, if necessary, move the sensor to the left or right, depending on where the black marks are on the supplies. The black marks on the supply should cover the square lens inside the sensor.

Printing

Before you print, make sure the printer is connected to the host with a communication cable.

The communication values at the printer must match those at the host.

The printer's default communication values are 9600 Baud, 8-bit data frame, 1 stop bit, no parity, and DTR flow control.

1. Turn on the printer.
2. Download a format and a batch. Refer to the *Packet Reference Manual* for information on downloading print jobs.
3. The printer prints the labels, either in peel mode or non-peel mode.
4. Remove the printed labels.

CARE & MAINTENANCE

3

This chapter tells you how to

- ◆ clear supply jams
- ◆ clean the printhead
- ◆ clean the platen roller and printer.

Clearing Supply Jams

When you are printing and a jam occurs, the indicator light turns RED. To clear the jam:

1. Turn off the printer. Press the switch on the back of the printer to the OFF position (O).
2. Press the cover release levers towards the front of the printer to release the cover.
3. Lift open the cover.
4. If necessary, remove any previously loaded supply. Lift up the supply holder and remove one of the supply holder guides.
5. Slide the supply off the holder.
6. Remove the jammed supply.

Caution: Do not use sharp or pointed objects to remove supply. This may damage the printhead.

7. Reload the supply. See Chapter 2, "Loading Supplies and Printing" for more information.
8. Close the cover until it locks in place.
9. Press the FEED button to clear the error. The indicator light should be GREEN.

Cleaning the Printhead

Clean the printhead whenever you notice a decline in print quality, or after using three rolls of supply.

Note: You must turn the printer's power off before cleaning the printhead. If you need to clean the printhead during a print job, you may lose your data when you turn off the printer.

1. Turn off the printer. Press the switch on the back of the printer to the OFF position (O).
2. Press the cover release levers towards the front of the printer to release the cover.
3. Lift open the cover.
4. Moisten a cotton swab with isopropyl alcohol.
5. Rub the cotton swab across the printhead to remove any build-up.

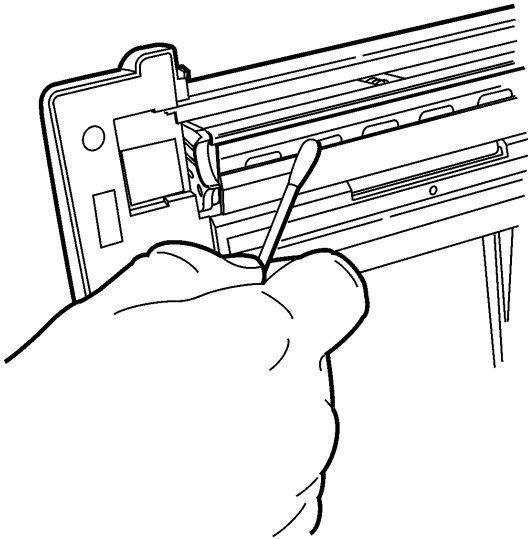

6. Allow the printhead to dry for one minute before you close the cover and resume printing.

Cleaning the Platen Roller and Printer

To clean the platen roller:

1. Turn off the printer.
2. Press the cover release levers towards the front of the printer to release the cover.
3. Lift open the cover.
4. Moisten a cotton swab with isopropyl alcohol and run the cotton swab across the platen roller.
5. Turn the platen roller with your finger and make sure it is clean all the way around.

Note: Do not remove the platen roller.

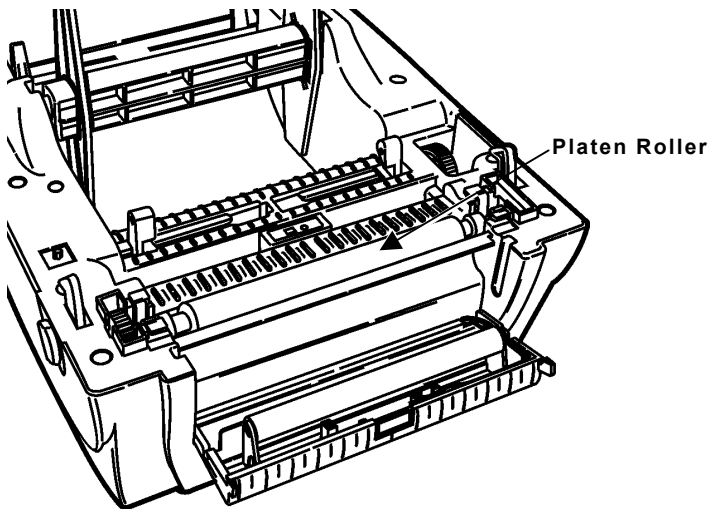

6. Allow the platen roller to dry for one minute before you close the cover and resume printing.
7. Slightly dampen a cloth with water and wipe the printer's exterior surfaces clean.
8. Use a dry, soft-bristled brush to clean paper dust out of the printer's interior. **Do not clean the inside of the printer with a damp cloth. Do not clean while the printer is on. Do not use household cleaners to clean the printer.**

TROUBLESHOOTING

4

This chapter includes information on

- ◆ possible printing problems and solutions
- ◆ printing test labels
- ◆ calibrating the supply.

Printing Problems and Solutions

This section lists some common problems and their solutions.

Problem	Action
Indicator light is off when the printer is turned on.	Check the power connections from the power supply to the printer and the AC outlet. See "Connecting the Power Supply" in Chapter 1, for more information.
Indicator light is GREEN, but the printer will not print.	Check the cable connections from the computer to the printer. "Connecting the Communication Cable" in Chapter 1, for more information.
	Verify that the supply is loaded correctly. See Chapter 2, "Loading Supplies and Printing," for more information.
	Clean the printhead. See "Cleaning the Printhead" in Chapter 3, for more information.
	Make sure the cover is closed completely.

Problem	Action
<p>Printing stops and indicator light turns RED. Or, Printing is not lined up correctly on supply.</p>	<p>Calibrate the supply.</p> <ol style="list-style-type: none"> 1. Turn off the printer. 2. Load supply for non-peel mode. See Chapter 2, "Loading Supplies and Printing," for more information. 3. Press and hold the FEED button while turning on the printer. 4. Release the FEED button after the indicator light starts flashing ORANGE. The printer calibrates the black mark or die cut sensor, measures the label length, and prints the test labels. 5. To resume normal printing, turn off the printer, wait two seconds, then turn it back on again.
	<p>Problem with the supply. Load different supply. See Chapter 2, "Loading Supplies and Printing," for more information.</p>
	<p>Clear a label jam. See "Clearing Supply Jams," in Chapter 3, for more information.</p>
	<p>Make sure the black mark/die cut sensor is set correctly for your supply type. See "Adjusting the Black Mark/Die Cut Sensor," for more information.</p>

Problem	Action
Printing is faded or poor quality.	Verify that supply is loaded correctly. See Chapter 2, "Loading Supplies and Printing," for more information.
	Clean the printhead. See "Cleaning the Printhead" in Chapter 3, for more information.
	Adjust the print speed/darkness (contrast). Refer to the <i>Packet Reference Manual</i> for more information.
Supply exits partially out of the printer or skips.	Supply might be caught in the printer. See "Clearing Supply Jams" in Chapter 3, for more information.
	Verify the supply is loaded correctly. See Chapter 2, "Loading Supplies and Printing," for more information.

Printing Test Labels

To print the test labels:

1. Turn off the printer.
2. Press and hold the **FEED** button while turning on the printer.
3. Release the **FEED** button after the indicator light starts flashing **ORANGE**. The test labels print.

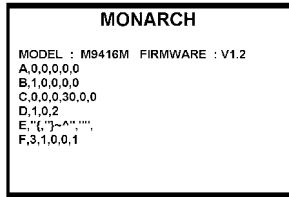

The first label shows the printer's configuration by packet (A-F). Refer to the *Packet Reference Manual* available on our Web site for more information.

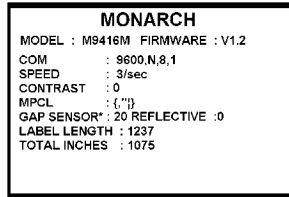

The second label shows the model number, software version, communication settings, speed, contrast, gap sensor setting, label length, and total number of inches printed.

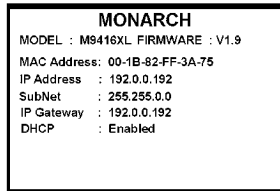

The third label shows network parameters when the printer is connected to the network. When the printer is not connected, zeros print instead of parameters.

4. To resume normal printing, turn off the printer, wait two seconds, then turn it back on again.

Calibrating the Supply

To calibrate the supply:

1. Turn off the printer.
2. Press and hold the **FEED** button while turning on the printer.
3. Release the **FEED** button after the indicator light starts flashing **ORANGE**. The printer calibrates the black mark or die cut sensor, measures the label length, and prints the test labels.
4. To resume normal printing, turn off the printer, wait two seconds, then turn it back on again.

SPECIFICATIONS & ACCESSORIES



This chapter includes

- ◆ printer specifications
- ◆ supply specifications
- ◆ printer accessories.

Printer Specifications

Height:	6.6" (168 mm)
Width:	8.3" (211 mm)
Depth:	9.4" (239 mm)
Weight:	4.1 lbs. (1.9 kg) without power supply
Shipping Weight:	9.0 lb. (4 kg)
Power:	U.S.: 120 VAC \pm 10%, 60Hz International: 220 VAC \pm 10%, 50Hz
Operating Limits:	Operating Thermal Direct: 40° to 105° F (4° to 40° C) Storage: 40° to 140° F (4° to 60° C)
Printhead:	4.09" (104 mm) 203 dpi (8.0 dots per mm)
Printing Method:	Thermal Direct

Supply Specifications

Supply Types: Labels, tags or receipt paper

Supply Widths: 0.75" (19 mm) minimum
4.25" (108 mm) maximum

Supply Lengths: 0.25" (6.3 mm) minimum
10.0" (254 mm) maximum

(for peel): 0.75" (19 mm) minimum
10.0" (254 mm) maximum

Note: Hold the leading edge of peeled labels when printing on supply longer than six inches.

Printer Accessories

Use these part numbers when ordering parts.

Description	Part Number
Centronics® Cable (IEEE 1284-B to 25-pin male)	118363
Serial Cable 6 feet (DB 9-pin male to DB 9-pin female)	300017-006
Parallel Cable 6 feet (DB 25-pin female to DB 9-pin male)	300018-006
USB V2.0 Cable (male)	125323

Visit **www.monarch.com** for sales, service, supplies, information, and telephone numbers for our locations throughout the world.

TOLL FREE:

1-800-543-6650 (In the U.S.A.)

1-800-363-7525 (In Canada)